

MPI TS3000-SE | 300 mm Automated Probe System

For accurate and reliable IV, CV, pulsed-IV, 1/f and RF Measurements

FEATURES / BENEFITS

Designed for Variety of On-Wafer Applications

- Device Modeling - DC-IV, DC-CV, Pulse-IV, ESD, 1/f
- RF and mmW - RF Setup from 26 GHz to 110 GHz & beyond
- Wafer Level Reliability - for accurate stress- and measure conditions
- Drivers for leading test executive software suits

MPI ShieldEnvironment™ for Accurate Measurements

- Advanced EMI / RFI / Light-tight Shielding for best 1/f noise test results
- Ultra-low noise IV measurements down to fA level
- Programmable microscope movements for test automation and ease of use
- Wide temperature range -60 °C to 300 °C with unique configuration flexibility

Ergonomic Design and Options

- Easy wafer or single DUT loading from the front
- Integrated active vibration isolation
- Completely integrated prober control for faster, safer and convenient system and test operation
- The Safety Test Management (STM™) with automated dew point control
- Reduced footprint due to smart integration of the chiller
- Instrument shelf option for shorter RF cables providing the highest measurement dynamic



STAGE SPECIFICATIONS

Chuck XY Stage (Programmable)

Travel range	310 mm x 335 mm (12.2 x 13.19 in)
Resolution	0.5 µm
Accuracy	± 2.0 µm (0.08 mils)
Repeatability	± 1.0 µm
XY stage drive	Closed-loop high precision stepper motors
Speed*	Slowest: 10 µm / sec Fastest: 50 mm / sec

Chuck Z Stage (Programmable)

Travel range	30 mm (1.18 in)
Resolution	0.2 µm
Accuracy	± 2.0 µm
Repeatability	± 1.0 µm
Z stage drive	Closed-loop high precision stepper motor
Speed*	Slowest: 10 µm / sec Fastest: 20 mm / sec
Guider	Precision ball bearings

*The speed is instantaneous speed, not average speed. There is accelerate and decelerate time when moving.

STAGE SPECIFICATIONS

Chuck Theta Stage (Programmable)

Travel range	± 5.0°
Resolution	0.0001° (0.24 µm @ 300mm edge)
Accuracy	< 2.0 µm (measured at the edge of the 300 mm chuck)
Repeatability	< 1.0 µm
Theta stage drive	High resolution stepper motor with linear encoder feedback system

MICROSCOPE MOVEMENT

XYZ Programmable

XY - Travel range*	50 x 50 mm / 300 x 300 mm
Resolution	1 µm (0.04 mils)
Repeatability	≤ 2 µm (0.08 mils)
Accuracy	≤ 5 µm (0.2 mils)
Z - Travel range	140 mm
Resolution	0.05 µm (0.002 mils)
Repeatability	≤ 2 µm (0.08 mils)
Accuracy	≤ 4 µm (0.16 mils)

*In case of ShieldEnvironment™ X x Y: 25 mm x 25 mm

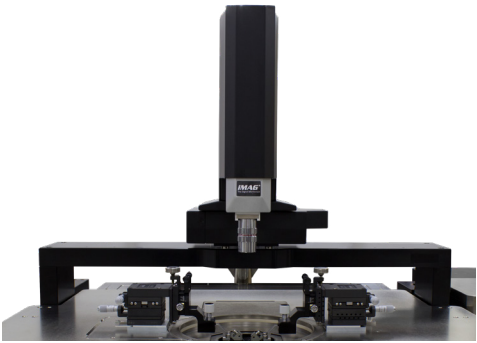

PROBE PLATEN

Specifications

Material	Nickel plated steel
Chuck to ShieldGuard height	min. 5 mm
Platen cooling	Fully integrated CDA cooling, by using the chiller CDA
Configuration	Probe card holder 4.5 x 7" and/or MicroPositioners
Max. No. of MicroPositioners	8x DC MicroPositioners or 4x DC + 4x RF MicroPositioner Setup
RF MicroPositioner mounting	Magnetic with guided rail
DC MicroPositioner mounting	Magnetic

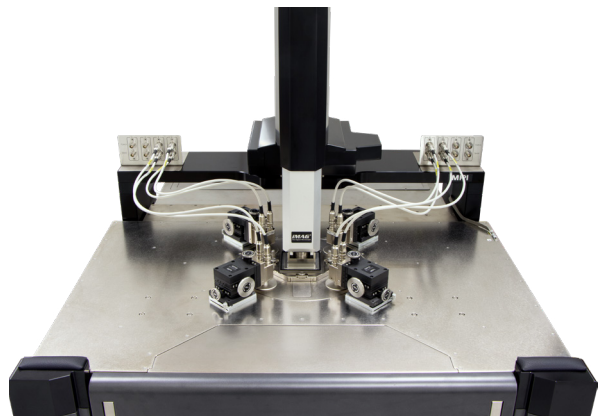
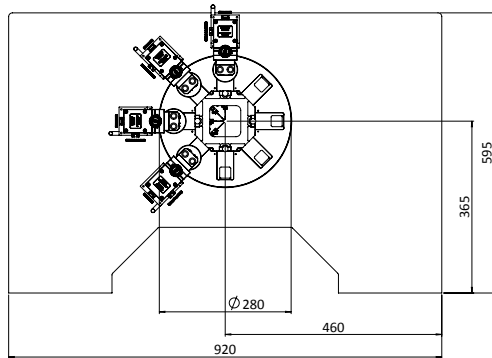

Large Probe Platen supporting up to 8x DC or 4x DC + 4x RF MicroPositioners or standard 4.5" probe card holder

ShieldEnvironment™

MPI ShieldEnvironment™ is a high performance local environmental chamber providing excellent EMI- and light-tight shielded test environment for ultra-low noise, low capacitance measurements. MPI ShieldEnvironment™ allows for testing with up to 4-port RF or up to 8-ports DC/Kelvin or a combination of those configurations. MPI ShieldCap™ provides easy reconfiguration of measurement setup as well as EMI/noise shielding - These all makes a great difference to conventional systems, especially in a day-to-day operation.

ShieldEnvironment™ Electrical Specifications*

EMI shielding	> 30 dB (typical) @ 1 kHz to 1 MHz
Light attenuation	≥ 130 dB
Spectral noise floor	≤ -180 dBVrms/rtHz (≤ 1 MHz)
System AC noise	≤ 5 mVp-p (≤ 1 GHz)

*Including 4 MicroPositioners.

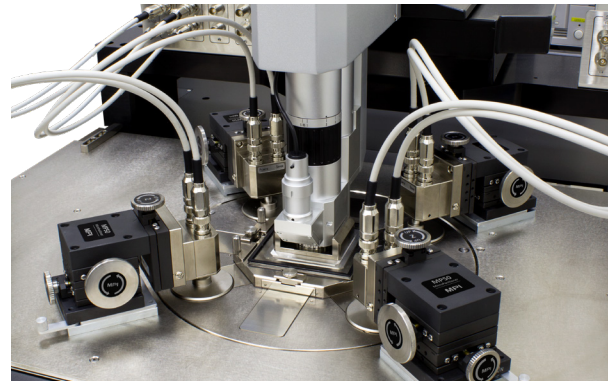
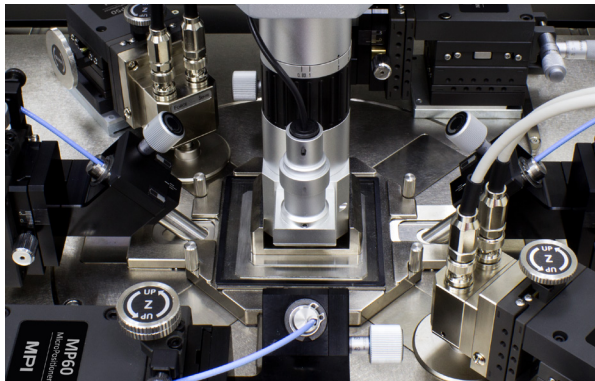

KEY FEATURES

Wafer Loading

Loading or unloading of 150, 200 or 300 mm wafers or substrates is straight forward and intuitive. Special design of the chuck provides easy loading of a single IC or wafer fragments from the system front. SmartVacuum™ technology automatically recognizes size of the wafer on single IC. It also protects the wafer from unexpected release of vacuum due to inexperienced operation when the wafer is located in the IceFreeEnvironment™. Easy access to the AUX chucks serves for quick exchange of RF calibration substrates, probe cleaning and planarization accessories.

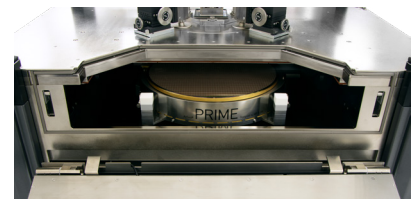

Integrated Controls

Thermal chuck touchscreen control display is an alternative way of interaction with the thermal system. Its ergonomic location supports an operator when keying commands and monitoring system status. The fully integrated intelligent hardware control panel is design for intuitive and safe system control and operation. All these significantly increase the speed and improve convenience of the system interaction work flow. The keyboard and mouse are placed on the sliding tray right below the system control panel. Both can control test instrumentation, if required. USB port is also in front of the system. It removes any hassles when exchanging data.



Minimized CDA Consumption

The CDA consumption is reduced by as much as 50% by purging IceFreeEnvironment™ with the re-used cold air of the chiller. Additional automated valve enables purge by Nitrogen*.

Additionally, recycled CDA cools the system probe platen and the probe card.

*ERS patented technology.

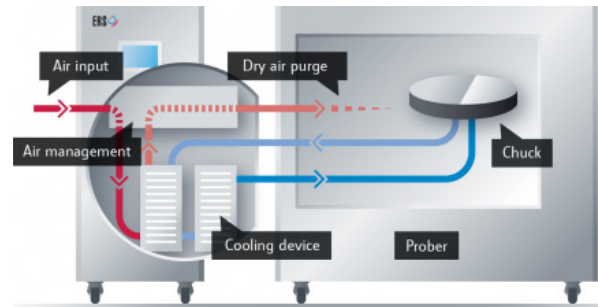

Picture is courteously provided by ERS.

OPTIONAL FEATURES

NoiseShield™

MPI's exclusive NoiseShield™ offers in combination with MPI ShieldEnvironment™ for unsurpassed active EMI-Shielding of DUT and the measurement instrument (such as pre-amplifier unit). In addition, it provides all cables and connectors close to DUT.

The NoiseShield™ option provides shortest possible cable lengths to reduce parasitic capacitance and to maximize test system roll-off frequency. It reduces external magnetic field influences on the measurement results and makes the 1/f, RTN Setup more robust and test lab location less independent.

Low impedance cables (for DC or RF pad design), excellent low-impedance system's grounding and ferrite cores on the unique MPI Kelvin probes are part of the delivery in order to make the probe station completely "invisible" and the measurement results to reach the limit of the instrumentation.

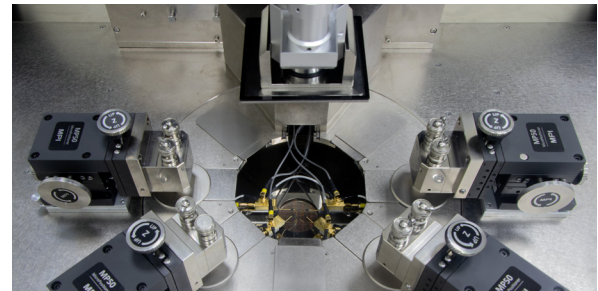
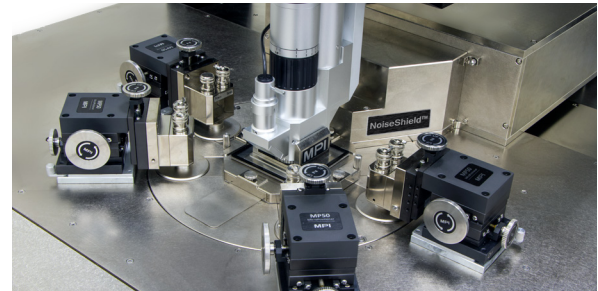

Probe Hover Control™

MPI Probe Hover Control PHC™ allows easy manual control of probe contact and separation to wafer. Separation distance can accurately control with micrometer feedback for probe to wafer/pad positioning. Ease of use guarantees the safest operation by minimizing error during critical set-up and probe change operations.



Automated Test Over Multiple Temperatures ATMT™

True to our mission of making complex probe station operation as intuitive as possible, minimizing training costs, and continuously focusing on reducing cost of test, MPI designed unique and cost-effective technologies, that enable Automated Test over Multiple Temperatures ATMT™. In combination with MPI's WaferWallet® or WaferWallet®MAX, Device Modeling and Wafer Level Reliability engineers will benefit from these features to generate significant more measurement data and will increase the entire Test Cell efficiency.

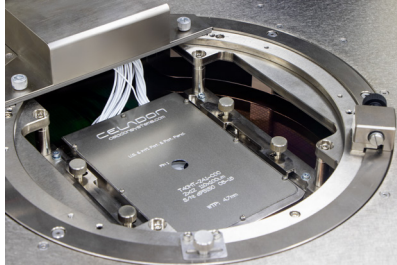

Celadon, high-performance, low-leakage probe cards

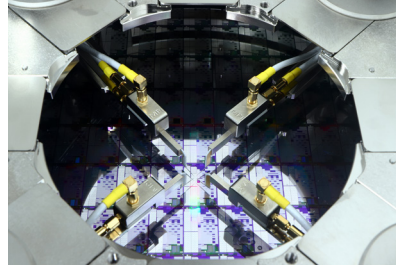

MPI Kelvin LTM high temperature probe arms

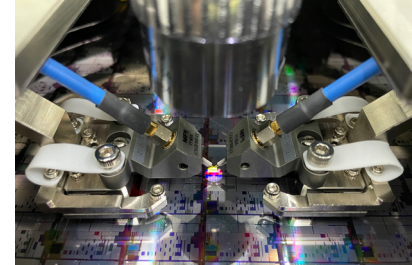

RF LTM probe arms, equipped with SmartCarrier™

ATMT™ DC

For DC over temperature measurements, Device Modeling and Wafer Level Reliability engineers are commonly using Celadon's, high temperature, low leakage probe cards. MPI and Celadon are finally offering leading edge, complete measurement solutions, enabling Automated Test over Multiple Temperatures ATMT™ DC at wide temperature range: -60...300°C. For the case of a few measurements performed with MicroPositioners, MPI has developed thermally stable Kelvin LTM probes that allow Automated Test over Multiple Temperatures ATMT™ at -40 to 175°C.

ATMT™ RF

MPI's SmartCarrier™ uniquely combines different materials that automatically compensate for the lateral expansions of the RF probes and the wafer without the need for complex software or programmable MicroPositioners*. SENTIO®'s new patent-pending ContactSense™ image processing can determine the new contact positions on-the-fly with an accuracy of a few micrometers, completing MPI's Automated Test over Multiple Temperatures ATMT™ RF.

*One programmable MicroPositioner is recommended for automated RF calibration by using QAlibria®

SOFTWARE SOLUTION

Unique and revolutionary multi-touch operation software SENTIO® controls MPI automated engineering probe systems. Its simple and intuitive operation concept significantly saves operator training time. Scroll, Zoon, and Move functions mimic modern smart mobile device interface. Switching between applications is just a matter of a simple finger swipe. SENTIO® makes everyone the system operation expert in just minutes.

By implementing intuitive multi-touch operation, QAlibria® provides crisp and clear guidance to the RF calibration process, minimizes configuration mistakes and helps to reach accurate calibration results in fastest time. QAlibria® offers industry standard and advanced calibration methods. QAlibria® includes TOSM (SOLT), TMR, TMRR methods, and 4-port calibration capability additionally to the integration of NIST StatistiCal calibration packages providing easy access to the NIST multiline TRL metrology-level calibration and uncertain analysis.

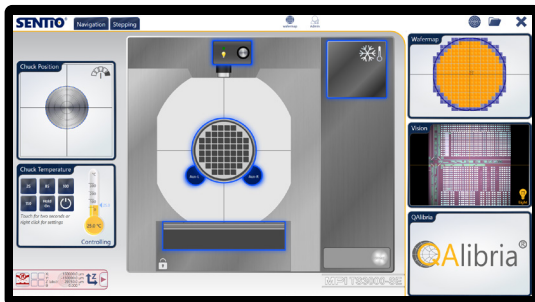

TYPICAL CONFIGURATION WITH MPI KELVIN AND MPI KELVIN-HIGH TEMPERATURE PROBES INSIDE SHIELD ENVIRONMENT™

	Coax Probe	Triax Probe	Kelvin Probe	Kelvin HT Probe
Max voltage	500 V	500 V	500 V	500 V
Temperature range	-60 °C to 300 °C	-60 °C to 300 °C	-60 °C to 200 °C	-60 °C to 200 / 300 °C
Leakage current	< 0.8 pA	< ± 20fA	< ± 10fA	< ± 10fA / < ± 20fA
Connectivity	SMB / BNC	Standard Triax	Kelvin Triax	Kelvin Triax
Connectivity type	Single, Coaxial	Single, low noise Triaxial	Force / Sense, low noise Triaxial	
Characteristics impedance	50 Ohms	50 Ohms	50 Ohms	50 Ohms
Residual capacitance	< 95 fF	< 95 fF	< 95 fF	< 95 fF
Probe holder material	Au-plated Brass		Au-plated Bras (Guarded)	
Probe tip type	Variety of metal tips		Coaxial / Guarded	Guarded ceramic blades
Probe tips material	W, BeCu, Au-plated		W	WRe
Probe tips radius	0.5 μm – 25 μm	0.5 μm – 25 μm	0.5 μm – 5 μm	2 μm – 5 μm
Minimum pad size	25 μm x 25 μm	25 μm x 25 μm	30 μm x 30 μm	25 μm x 25 μm

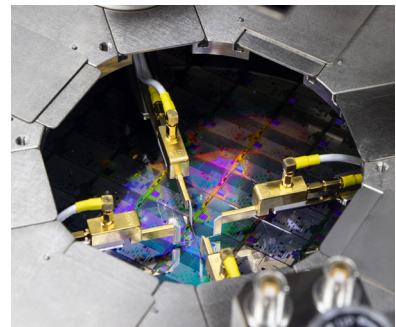
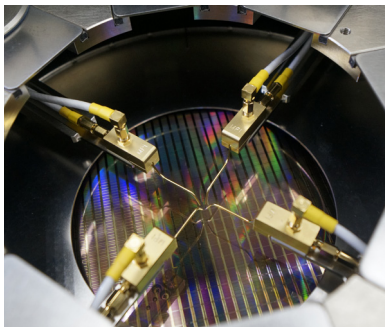

Typical MPI configuration with Kelvin Probes

NON-THERMAL CHUCKS

Wafer Chuck	Standard	Triaxial
Connectivity	Coax BNC (f)	Kelvin Triax (f)
Diameter	310 mm with 2 integrated AUX areas	
Material	Nickel plated aluminum (flat with 0.5 mm holes)	
Chuck surface	Planar with 0.5 mm diameter holes in centric sections	
Vacuum holes sections (diameter)	4, 24, 48, 72, 96, 120, 144, 168, 192, 216, 240, 264, 288 mm	
SmartVacuum™ distribution	In front for single DUT 4x4 mm (4 holes) and 75 mm (3 in) In center for 150, 200, 300 mm (6, 8, 12 in)	
Surface planarity	≤± 5 μm**	
Rigidity	< 15 μm / 10 N @edge	

*Single DUT testing requires higher vacuum conditions dependent upon testing application.

**By using SENTIO® topography

Triaxial RF Wafer Chuck

Connectivity	Kelvin Triax (f)
Diameter	310 mm with 2 integrated AUX chucks
Material	Nickel plated aluminum (flat with 0.5 mm holes)
Chuck surface	Planar with 0.5 mm diameter holes in centric sections
Vacuum holes sections (diameter)	4, 24, 48, 72, 96, 120, 144, 168, 192, 216, 240, 264, 288 mm
SmartVacuum™ distribution	In front for single DUT 4x4 mm (4 holes) and 75 mm (3 in) In center for 150, 200, 300 mm (6, 8, 12 in)
Surface planarity	≤± 5 μm**
Rigidity	< 15 μm / 10 N @edge

*Single DUT testing requires higher vacuum conditions dependent upon testing application.

**By using SENTIO® topography

Auxiliary Chuck

Quantity	2 AUX chucks
Position	Integrated to front side of main chuck
Substrate size (W x L)	Max. 25 x 25 mm (1 x 1 in)
Material	Ceramic, RF absorbing material for accurate calibration
Surface planarity	≤± 5 μm
Vacuum control	Controlled independently, separate from chucks

Electrical Specification (Coax)

Operation voltage	In accordance with EC 61010, certificates for higher voltages available upon request
Maximum voltage between chuck top and GND	500 V DC
Isolation	> 2 GΩ

Electrical Specification (Triax)

Chuck Isolation	At 10 V
Force-to-Guard	> 5 T Ohm
Guard-to-Shield	> 1 T Ohm
Force-to-Shield	> 5 T Ohm

THERMAL CHUCKS

Specifications of MPI ERS AirCool® PRIME Technology

	Ambient to 200/300 °C	20 °C to 200/300 °C	Ambient to 200/300 °C	20 °C to 200/300 °C
Chuck type	RF	RF	Ultra low noise	Ultra low noise
Connectivity	Kelvin Triax (f)	Kelvin Triax (f)	Kelvin Triax (f)	Kelvin Triax (f)
Temperature control method	Cooling air / Resistance heater	Cooling air / Resistance heater	Cooling air / Resistance heater	Cooling air / Resistance heater
Coolant	Air (user supplied)	Air (user supplied)	Air (user supplied)	Air (user supplied)
Smallest temperature selection step	0.1 °C	0.1 °C	0.1 °C	0.1 °C
Chuck temperature display resolution	0.01 °C	0.01 °C	0.01 °C	0.01 °C
External touchscreen display operation	Yes	Yes	Yes	Yes
Temperature stability	±0.5 °C	±0.05 °C	±0.05 °C	±0.05 °C
Temperature accuracy	±0.1 °C	0.1 °C	0.1 °C	0.1 °C
Control method	Low noise DC/PID	Low noise DC/PID	Low noise DC/PID	Low noise DC/PID
Chuck pinhole surface plating: 200°C / 300°C	Nickel / Gold	Nickel / Gold	Nickel / Gold	Nickel / Gold
SmartVacuum™ distribution	In front for single DUT 4x4 mm (4 holes) and 75 mm (3 in) In center for 150, 200, 300 mm (6, 8, 12 in)			
Temperature sensor	Pt100 1/3DIN, 4-line wired	Pt100 1/3DIN, 4-line wired	Pt100 1/3DIN, 4-line wired	Pt100 1/3DIN, 4-line wired
Temperature uniformity	< ±0.5 °C at ≤ 200 °C < ±1 °C at > 200 °C	< ±0.5 °C at ≤ 200 °C < ±1 °C at > 200 °C	< ±0.5 °C at ≤ 200 °C < ±1 °C at > 200 °C	< ±0.5 °C at ≤ 200 °C < ±1 °C at > 200 °C
Surface flatness and base parallelism	< ±12 μm	< ±12 μm	< ±12 μm	< ±12 μm
Max. Voltage between				
Force-to-GND	600 V DC	600 V DC	600 V DC	600 V DC
Force-to-Guard	100 V DC	100 V DC	600 V DC	600 V DC
Heating rates	35 to 200 °C < 15 min 35 to 300 °C < 25 min	20 to 200 °C < 18 min 20 to 300 °C < 28 min	35 to 200 °C < 18 min 35 to 300 °C < 28 min	20 to 200 °C < 20 min 20 to 300 °C < 30 min
Cooling rates*	200 to 35 °C < 28 min 300 to 35 °C < 35 min	200 to 20 °C < 30 min 300 to 20 °C < 38 min	200 to 35 °C < 30 min 300 to 35 °C < 38 min	200 to 20 °C < 33 min 300 to 20 °C < 40 min
Leakage @ 10 V	N/A	N/A	< 15 fA at 25 °C < 30 fA at 200 °C < 50 fA at 300 °C	< 15 fA at 25 °C < 30 fA at 200 °C < 50 fA at 300 °C
Electrical isolation	> 5 T Ω at 25 °C > 1 T Ω at 200 °C > 0.5 T Ω at 300 °C	> 5 T Ω at 25 °C > 1 T Ω at 200 °C > 0.5 T Ω at 300 °C	N/A	N/A
Capacitance				
Force-to-Guard	< 1600 pF	< 1600 pF	< 600 pF	< 600 pF
Guard-to-Shield	< 2000 pF	< 2000 pF	< 2000 pF	< 2000 pF

* All data are relevant for chucks in ECO mode.

Specifications of MPI ERS AirCool® PRIME Technology

	-10 °C to 200/300 °C	-40 °C to 200/300 °C	-60 °C to 200/300 °C
Chuck type	Ultra low noise	Ultra low noise	Ultra low noise
Connectivity	Kelvin Triax (f)	Kelvin Triax (f)	Kelvin Triax (f)
Temperature control method	Cooling air / Resistance heater	Cooling air / Resistance heater	Cooling air / Resistance heater
Coolant	Air (user supplied)	Air (user supplied)	Air (user supplied)
Smallest temperature selection step	0.1 °C	0.1 °C	0.1 °C
Chuck temperature display resolution	0.01 °C	0.01 °C	0.01 °C
External touchscreen display operation	Yes	Yes	Yes
Temperature stability	±0.08 °C	±0.08 °C	±0.08 °C
Temperature accuracy	0.1 °C	0.1 °C	0.1 °C
Control method	Low noise DC/PID	Low noise DC/PID	Low noise DC/PID
Interfaces	RS232C	RS232C	RS232C
Chuck pinhole surface plating: 200°C / 300°C	Nickel / Gold	Nickel / Gold	Nickel / Gold
SmartVacuum™ distribution	In front for single DUT 4x4 mm (4 holes) and 75 mm (3 in) In center for 150, 200, 300 mm (6, 8, 12 in)		
Temperature sensor	Pt100 1/3DIN, 4-line wired	Pt100 1/3DIN, 4-line wired	Pt100 1/3DIN, 4-line wired
Temperature uniformity	< ±0.5 °C at ≤ 200 °C < ±1 °C at > 200 °C	< ±0.5 °C at ≤ 200 °C < ±1 °C at > 200 °C	< ±0.5 °C at ≤ 200 °C < ±1 °C at > 200 °C
Surface flatness and base parallelism	< ±12 μm	< ±12 μm	< ±12 μm
Max. Voltage between			
Force-to-GND	600 V DC	600 V DC	600 V DC
Force-to-Guard	600 V DC	600 V DC	600 V DC
Heating rates			
25 °C	-10 to 25 °C < 10 min	-40 to 25 °C < 12 min	-60 to 25 °C < 15 min
200 °C		25 to 200 °C < 20 min	
300 °C		25 to 300 °C < 35 min	
Cooling rates*			
300 °C	300 to 25 °C < 38 min	300 to 25 °C < 35 min	
200 °C	200 to 25 °C < 30 min	200 to 25 °C < 25 min	
25 °C	25 to -10 °C < 30 min	25 to -40 °C < 65 min	25 to -60 °C < 45 min
Leakage @ 10 V			
-10, -40 or -60 °C	< 30 fA	< 30 fA	< 30 fA
25 °C	< 15 fA	< 15 fA	< 15 fA
200 °C	< 30 fA	< 30 fA	< 30 fA
300 °C	< 50 fA	< 50 fA	< 50 fA
Capacitance			
Force-to-Guard	< 600 pF	< 600 pF	< 600 pF
Guard-to-Shield	< 2000 pF	< 2000 pF	< 2000 pF

* All data are relevant for chucks in ECO mode.

Specifications of MPI ERS AirCool® PRIME Technology

	-10 °C to 200/300 °C	-40 °C to 200/300 °C	-60 °C to 200/300 °C
Chuck type	RF	RF	RF
Connectivity	Kelvin Triax (f)	Kelvin Triax (f)	Kelvin Triax (f)
Temperature control method	Cooling air / Resistance heater	Cooling air / Resistance heater	Cooling air / Resistance heater
Coolant	Air (user supplied)	Air (user supplied)	Air (user supplied)
Smallest temperature selection step	0.1 °C	0.1 °C	0.1 °C
Chuck temperature display resolution	0.01 °C	0.01 °C	0.01 °C
External touchscreen display operation	Yes	Yes	Yes
Temperature stability	±0.08 °C	±0.08 °C	±0.08 °C
Temperature accuracy	0.1 °C	0.1 °C	0.1 °C
Control method	Low noise DC/PID	Low noise DC/PID	Low noiseDC/PID
Interfaces	RS232C	RS232C	RS232C
Chuck pinhole surface plating: 200°C / 300°C	Nickel / Gold	Nickel / Gold	Nickel / Gold
SmartVacuum™ distribution	In front for single DUT 4x4 mm (4 holes) and 75 mm (3 in) In center for 150, 200, 300 mm (6, 8, 12 in)		
Temperature sensor	Pt100 1/3DIN, 4-line wired	Pt100 1/3DIN, 4-line wired	Pt100 1/3DIN, 4-line wired
Temperature uniformity	< ±0.5 °C at ≤ 200 °C < ±1 °C at > 200 °C	< ±0.5 °C at ≤ 200 °C < ±1 °C at > 200 °C	< ±0.5 °C at ≤ 200 °C < ±1 °C at > 200 °C
Surface flatness and base parallelism	< ±12 μm	< ±12 μm	< ±12 μm
Max. Voltage between			
Force-to-GND	600 V DC	600 V DC	600 V DC
Force-to-Guard	100 V DC	100 V DC	100 V DC
Heating rates			
25 °C	-10 to 25 °C < 8 min	-40 to 25 °C < 10 min	-60 to 25 °C < 12 min
200 °C		25 to 200 °C < 18 min	
300 °C		25 to 300 °C < 30 min	
Cooling rates*			
300 °C	300 to 25 °C < 35 min	300 to 25 °C < 32 min	
200 °C	200 to 25 °C < 28 min	200 to 25 °C < 22 min	
25 °C	25 to -10 °C < 28 min	25 to -40 °C < 55 min	25 to -60 °C < 40 min
Leakage @ 10 V	N/A	N/A	N/A
Electrical isolation		> 5 T Ω at 25 °C or below > 1 T Ω at 200 °C > 0.5 T Ω at 300 °C	
Capacitance			
Force-to-Guard	< 1600 pF	< 1600 pF	< 1600 pF
Guard-to-Shield	< 2000 pF	< 2000 pF	< 2000 pF

* All data are relevant for chucks in ECO mode.

High Temperature Uniformity Option*

HTU Option	-60 °C		-50 °C		-35 °C		0 °C	
	typical	max	typical	max	typical	max	typical	max
Accuracy	±0.015	±0.05	±0.015	±0.05	±0.015	±0.05	±0.02	±0.05
Uniformity	±0.4	±0.5	±0.4	±0.5	±0.3	±0.5	±0.15	±0.2

HTU Option	35 °C		50 °C		70 °C	
	typical	max	typical	max	typical	max
Accuracy	±0.02	±0.05	±0.02	±0.05	±0.025	±0.05
Uniformity	±0.08	±0.1	±0.08	±0.1	±0.09	±0.1

* Only for RF thermal chucks.

THERMAL CHUCKS DIMENSIONS

System Controller / Chiller Dimensions and Power / Air Consumption

System type	W x D x H (mm)	Weight (kg)	Power cons. (VA)	max. Air flow* (l/min)	CDA dew Point
Ambient	300 x 360 x 135	12	1200	400	≤ 0 °C
20 °C, -10 °C to 200 / 300 °C	300 x 360 x 135	12	1200	400	≤ -30 °C
-40 to 200 / 300 °C	420 x 300 x 520	45	1200	400	≤ -40 °C
-60 to 200 / 300 °C	420 x 500 x 1020	140	2400	450	≤ -40 °C
Electrical primary connection	100 to 240 VAC auto switch				
Electrical frequency	50 Hz / 60 Hz				
Compressed air supply	6.0 bar (0.8 MPa, 87 psi)				



ERS AirCool® (patented) Controller Integrated Chiller -60 °C



ERS AirCool® (patented) Controller Integrated Chiller -40 °C



ERS and MPI's joint product AirCool® PRIME Chuck won "Electronics Industry Awards 2018" in the category, "Test, Measurement and Inspection Product of the year".

TYPICAL TRANSITION TIME

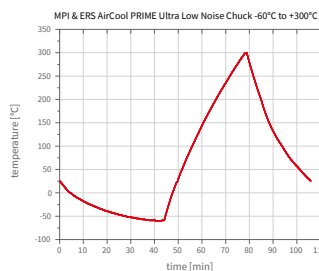
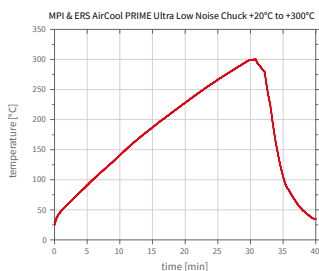
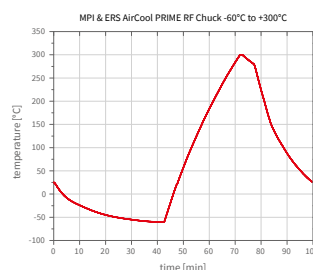
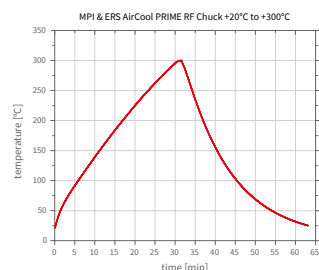

SYSTEM CONTROLLER SPECIFICATIONS

CPU	Intel® Core™ i7-7700, 3.6 GHz, 8M Cache, 14nm, 65W TDP, LGA1151 (4C/8T)
RAM	DDR4 2400 MHz 16 GB x 1
64 bit operating system	Windows 10 Professional (English)
Power	460 W
Storage	SSD 500 GB
LAN	One internal and one external TCP/IP ports
USB Ports	Internal (on PC) x3, external x1
GPIB interface	Optional

SUPPORTED SOFTWARE PLATFORMS

Drivers	WaferPro / IC-CAP & EasyEXPERT from Keysight, BSIMPro & NoisePro from ProPlus, ACS from Keithley
Emulation mode	Available for various prober control software*

* Please contact your local support for more details.

FACILITY REQUIREMENTS

General Probe System

Power	100-240 V AC nominal ; 50/60 Hz
Vacuum	-0.9 bar
Compressed air	6.0 bar

REGULATORY COMPLIANCE

3rd party, TÜV tested according to

- IEC 61010-1: 2010 + Am1:2016; EN 61010-1: 2010; IEC/EN 61010-2-010: 2014; IEC/EN 61010-2-081: 2015; EN ISO 12100: 2010; UL 61010-1: 2012/R: 2016-04; UL 61010-2-010: 2015; CAN/CSA-C22.2 No. 61010-1: 2012/U2: 2016-04; CAN/CSA-C22.2 No. 61010-2-010:2015

and certified for CE and US/Canada (NRTL), SEMI S2 and S8.

Copies of certificates are available on request

WARRANTY

- Warranty*: 12 months
- Extended service contract: contact MPI Corporation for more information

*See MPI Corporation's Terms and Conditions of Sale for more details.

PHYSICAL DIMENSIONS

TS3000-SE

System dimensions (W x D x H)	1400 x 1115 x 1000 / 1550 mm (55.1 x 43.9 x 39.4 / 61.0 in)
Weight	830 kg

*Can increase depends on operator manual adjustment or interaction.

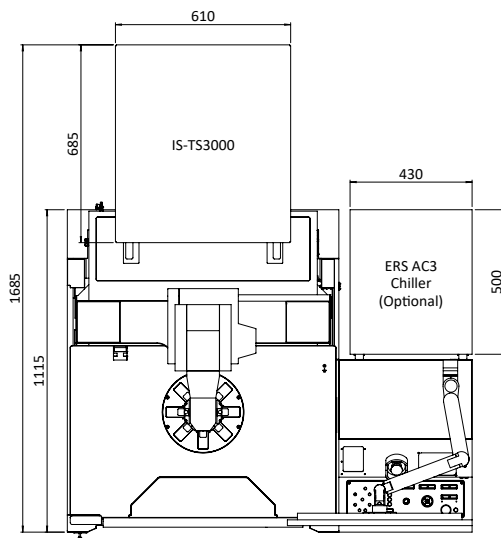
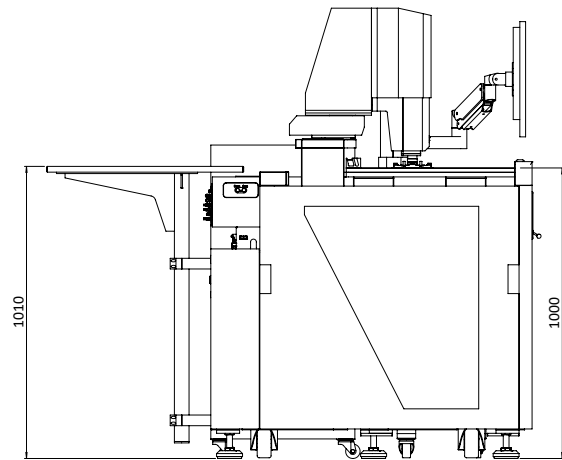
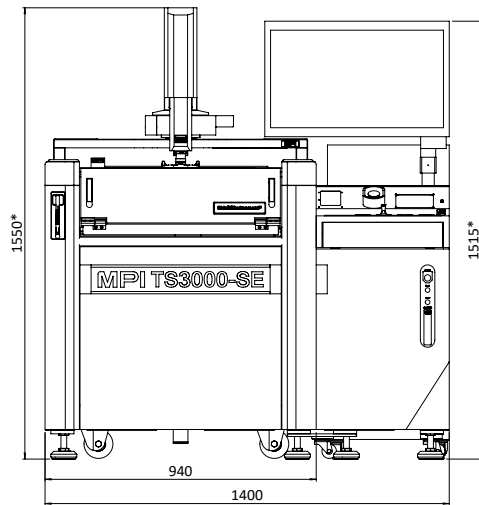

Direct contact:
 Asia region: ast-asia@mpi-corporation.com
 EMEA region: ast-europe@mpi-corporation.com
 America region: ast-americas@mpi-corporation.com

MPI global presence: for your local support, please find the right contact here:
www.mpi-corporation.com/ast/support/local-support-worldwide

© 2022 Copyright MPI Corporation. All rights reserved.

MPI Global Presence

